

Thank you for purchasing MEIJI Digital Air Regulator.

## Before Using this Product

- To ensure safe and proper use of this product, be sure to read through this instruction manual, and understand its content thoroughly before using the product.
- After reading this manual, keep it in place for your quick reference whenever required.
- To lend or transfer this product, attach this manual to the product.
- If this manual has been lost or damaged, immediately order a new one from our authorized dealer or distributor.
- To improve the product quality or performance or to ensure safety, the parts used in the product are subject to change. In this case, note that the description and some parts in the illustrations may be different from those of the actual product.
- If you have any question or comment about the product, contact the distributor of this product or our authorized dealer or distributor in your district.



### Caution

Indicates a case where failure in observing the advice on proper handling manners, or neglecting appropriate precautions may result in injury and/or serious damage to the product. Defects resulting from improper use are not covered by warranty.

- The original battery included is a test battery. If the battery runs out, please replace the battery by referring to the battery replacement method. (Button Battery - CR2032)

## Installation

1. Disconnect the compressed air supply.
2. Install regulator outlet connector onto the spray gun.
3. Connect the regulator inlet to an air hose connector.
4. Turn on air supply.
5. To adjust the air regulator pressure.
  - Pull the knob and turn.

**Clockwise ⇒ increase(+)pressure**

**Counterclockwise ⇒ decrease(-)pressure**

6. Push the knob down to lock the air pressure setting

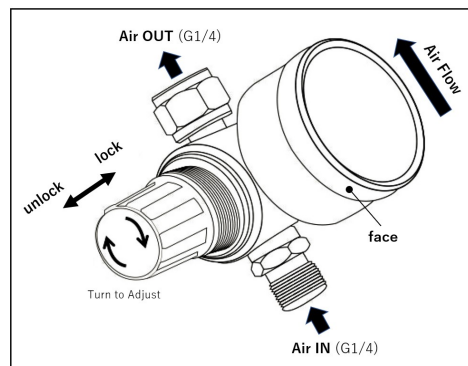

## Operation Instruction

- It may be damaged or deformed if the product is dropped or impacted.
- This is an auto ON/OFF air adjusting pressure gauge. If the gauge detects a change of pressure above 0.02MPa, the gauge will automatically turn on. The pressure gauge will remain on for the full duration of the spray gun use. The gauge will turn off once air pressure is below 0.02MPa.



**When not in use, please be sure to turn the knob to set the display pressure of the regulator to 0 and stop the supply of compressed air to the regulator. If compressed air is supplied, the power will remain ON and may lead to loss of battery.**

## Handling

- When attaching to a spray gun, tighten with a tool.

## Battery Replacement

1. Turn the "face" counter wise (See Figure 1.2)
2. Use a small tool to push battery out as shown on the circuit board (See Figure 2)
3. Insert a new **CR2032** battery with (-) facing upwards.
4. When a new battery is installed correctly, the power goes on after 5 seconds and then automatically go to rest process.
5. Push and turn the face of the gauge clock wise. When tightening, face of the gauge must be horizontal.

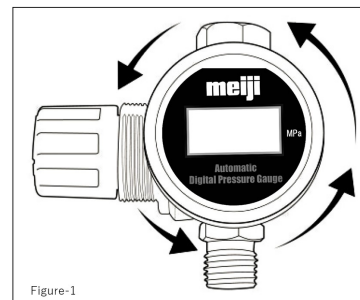

Figure-1

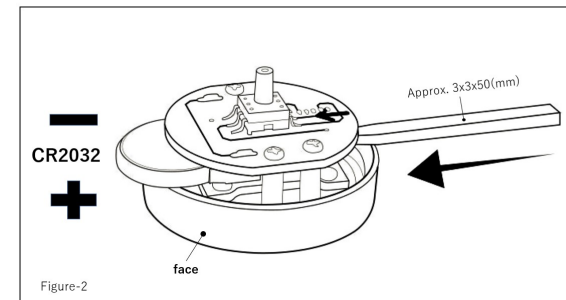

Figure-2

**✘ Please be sure to stop the supply of compressed air when replacing the battery.**

## Reset

- Remove and reinsert the battery will reset the gauge to zero.

## Specifications

Model	MARD
Name	Digital Air Regulator
Pressure Gauge Range (MPa)	0.02-1.1
Operating Resolution (°C)	0-50
Connection diameter	G1/4
Weight(g)	113

➤ **1MPa=145.038psi / 0.2MPa=29psi**